

PROPERTY OF

PPI IS NOT RESPONSIBLE FOR PRODUCT COMPATABILITY.
NOT ALL MATERIALS ARE SUITABLE FOR ALL APPLICATIONS.



PARKWAY PLASTICS

IT IS THE BUYER'S SOLE RESPONSIBILITY TO TEST THE COMPATIBILITY
OF THEIR PRODUCTS WITH PARKWAY'S PRODUCTS & SERVICES.

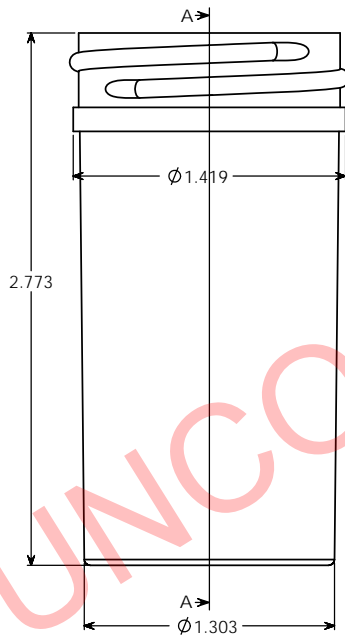
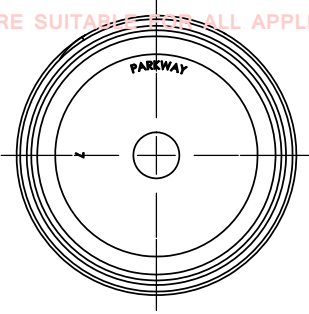

NOTE

=====
Manufacturer reserves the right to change specifications without notice. All purchase order for the item herein described, must be accompanied by a copy of this print. All dimensions have a tolerance of +/- 3% unless otherwise specified.
SIDEWALL CAMBER .050" PER SIDE MAX.
THREAD = GCM1 400- CT FINISH
6 THREADS PER INCH.

OVERFLOW: 54 ML
WEIGHT: 10 GRAMS ± 1 GRAM

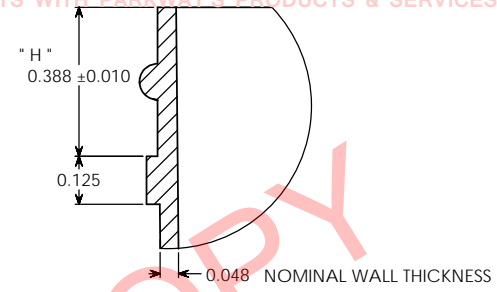

DETAIL B
SCALE 4 : 1

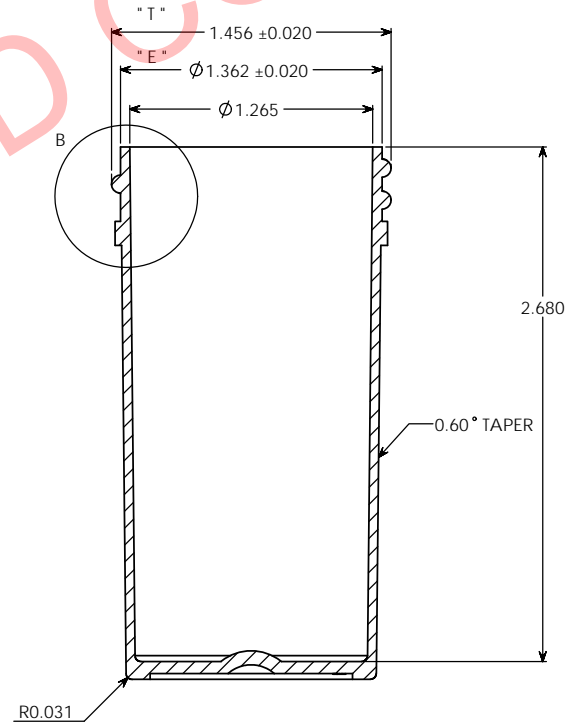

SECTION A-A

PROPRIETARY AND CONFIDENTIAL
THE INFORMATION CONTAINED IN THIS DRAWING IS THE SOLE PROPERTY OF PARKWAY PLASTICS INC. ANY REPRODUCTION IN PART OR AS A WHOLE WITHOUT THE WRITTEN PERMISSION OF PARKWAY PLASTICS INC IS PROHIBITED.

* T * DIMENSION	1.456 ± 0.020	UNLESS OTHERWISE SPECIFIED: DIMENSIONS ARE IN INCHES TOLERANCES: FRACTIONAL ± ANGULAR MATCH ± BEND ± TWO PLACE DECIMAL ± THREE PLACE DECIMAL ±	NAME	DATE	PARKWAY PLASTICS INC
* E * DIMENSION	1.362 ± 0.020		DRAWN	G.W.W	
* H * DIMENSION	0.388 ± 0.010		CHECKED		TITLE:
SECTION VIEW A-A	JAR		ENG APPR		1 1/2 OZ 38 MM REGULAR WALL WHITE POLYPROPYLENE JAR (CUSTOMER PRINT)
DETAIL VIEW B	* H * DIMENSION	MATERIAL	MFG APPR		SIZE DWG. NO.
		S11	DIA.		C A0380150PPW
		61 WHITE	COMMENTS		REV
NEXT ASSY	USED ON	DECORATION			SCALE: 2:1
		NA			WEIGHT:
APPLICATION	DO NOT SCALE DRAWING				SHEET 1 OF 1