

PROPERTY OF

PPI IS NOT RESPONSIBLE FOR PRODUCT COMPATABILITY.
NOT ALL MATERIALS ARE SUITABLE FOR ALL APPLICATIONS.



PARKWAY PLASTICS

IT IS THE BUYER'S SOLE RESPONSIBILITY TO TEST THE COMPATIBILITY
OF THEIR PRODUCTS WITH PARKWAY'S PRODUCTS & SERVICES.

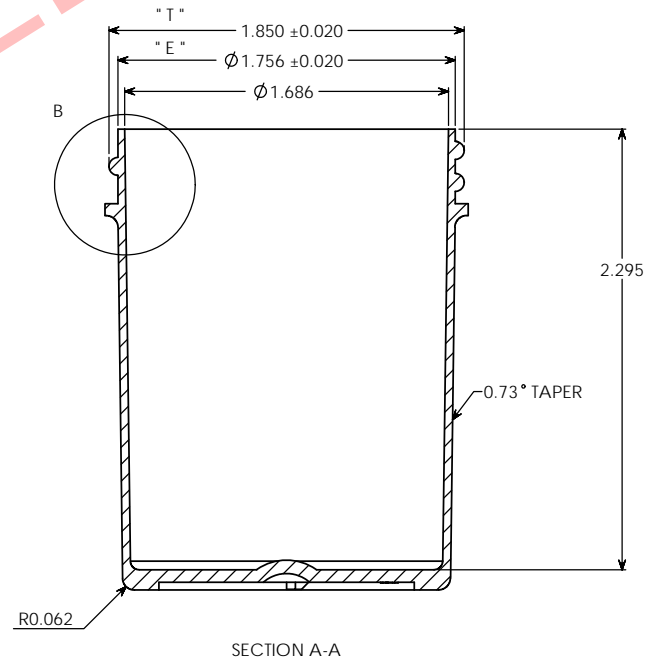
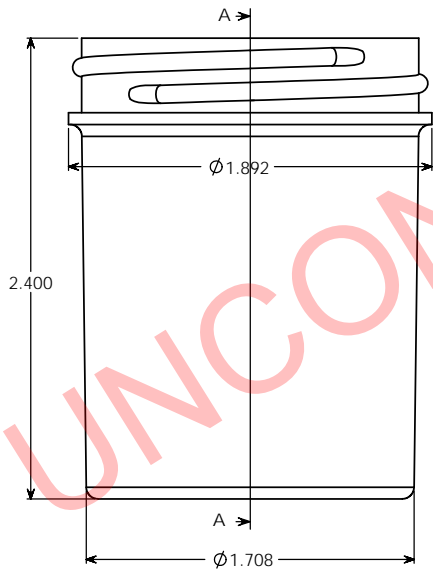
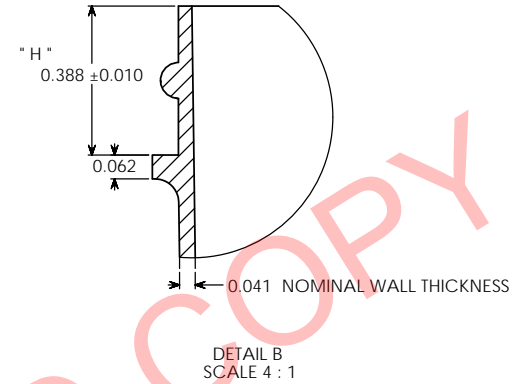
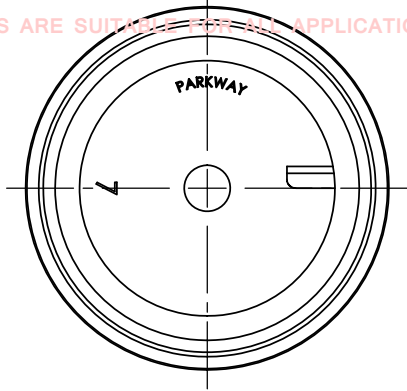

NOTE

Manufacturer reserves the right to change specifications without notice. All purchase order for the item herein described, must be accompanied by a copy of this print. All dimensions have a tolerance of +/- 3% unless otherwise specified.
SIDEWALL CAMBER .050" PER SIDE MAX.
THREAD = GCM1 400-CT FINISH
6 THREADS PER INCH.

OVERFLOW: 79 ML
WEIGHT: 12 GRAMS ± 2 GRAMS

UNCONTROLLED COPY

PROPRIETARY AND CONFIDENTIAL
THE INFORMATION CONTAINED IN THIS DRAWING IS THE SOLE PROPERTY OF PARKWAY PLASTICS INC. ANY REPRODUCTION IN PART OR AS A WHOLE WITHOUT THE WRITTEN PERMISSION OF PARKWAY PLASTICS INC IS PROHIBITED.

"T" DIMENSION	1.850 ± 0.020	UNLESS OTHERWISE SPECIFIED:	NAME	DATE	PARKWAY PLASTICS INC	
"E" DIMENSION	1.756 ± 0.020	DIMENSIONS ARE IN INCHES	DRAWN	G.W.W		01/09/13
"H" DIMENSION	0.388 ± 0.020	FRACTIONAL ±	CHECKED			
SECTION VIEW A-A	JAR	ANGULAR MATCH ± BEND ±	ENG APPR			
DETAIL VIEW B	"H" DIMENSION	TWO PLACE DECIMAL ±	MFG APPR			
		THREE PLACE DECIMAL ±	D.A.			
		MATERIAL	COMMENTS			
		U11	REPLACES PRINT # 248SRWJ2			
		COLOR/DRN				
		DECORATION				
NEXT ASSY	USED ON	NA				
APPLICATION	DO NOT SCALE DRAWING					
TITLE:					2 OZ 48 MM REGULAR WALL STYRENE JAR (CUSTOMER PRINT)	
SIZE	DWG. NO.	REV				
C	A0480200CSC					
SCALE: 2:1	WEIGHT:	SHEET 1 OF 1				