

PROPERTY OF

PPI IS NOT RESPONSIBLE FOR PRODUCT COMPATABILITY.
NOT ALL MATERIALS ARE SUITABLE FOR ALL APPLICATIONS.



PARKWAY PLASTICS

IT IS THE BUYER'S SOLE RESPONSIBILITY TO TEST THE COMPATIBILITY
OF THEIR PRODUCTS WITH PARKWAY'S PRODUCTS & SERVICES.

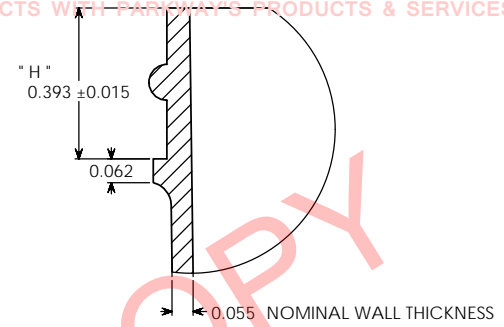
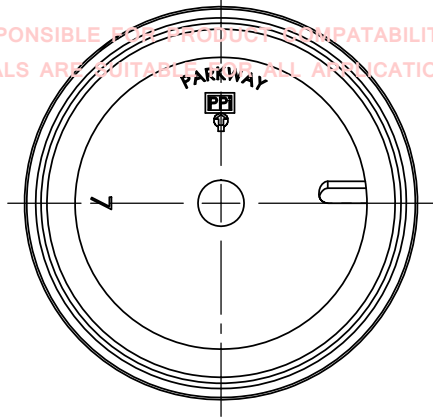

DETAIL B
SCALE 4 : 1

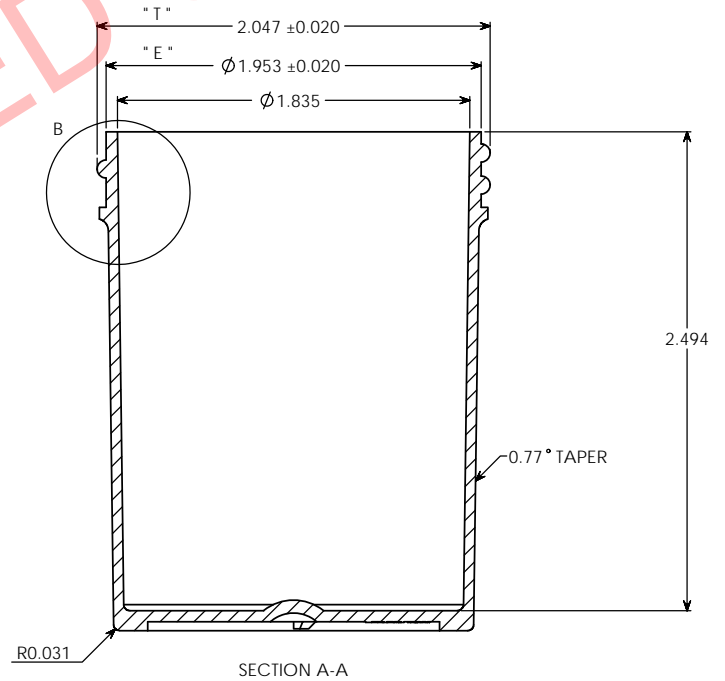
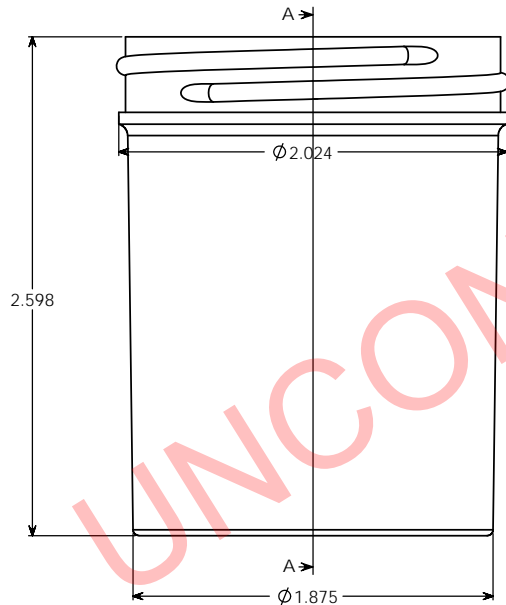

NOTE

Manufacturer reserves the right to change specifications without notice. All purchase order for the item herein described, must be accompanied by a copy of this print. All dimensions have a tolerance of +/- 3 % unless otherwise specified.
SIDEWALL CAMBER .050" PER SIDE MAX.
THREAD = GCM1 400- CT FINISH
6 THREADS PER INCH.

OVERFLOW: 100 ML
WEIGHT: 16 GRAMS ± 2 GRAMS

* T * DIMENSION	2.047 ± 0.020	UNLESS OTHERWISE SPECIFIED:	NAME	DATE	PARKWAY PLASTICS INC
* E * DIMENSION	1.953 ± 0.020	DIMENSIONS ARE IN INCHES	G.W.W	01/15/13	
* H * DIMENSION	0.393 ± 0.015	TOLERANCES:	CHECKED		TITLE:
SECTION VIEW A - A	JAR	FRACTIONAL ±	ENG APPR		3 OZ 53 MM REGULAR WALL POLYPROPYLENE JAR (CUSTOMER PRINT)
DETAIL VIEW B	* H * DIMENSION	ANGULAR MATCH ± BEND ±	MFG APPR		SIZE
		TWO PLACE DECIMAL ±	D.A.		C
		THREE PLACE DECIMAL ±	COMMENTS:		DWG. NO.
					A0530300PPC
					REV
					# 353PPRW
APPLICATION	DO NOT SCALE DRAWING				SCALE: 2:1
					WEIGHT:
					SHEET 1 OF 1

PROPRIETARY AND CONFIDENTIAL
THE INFORMATION CONTAINED IN THIS DRAWING IS THE SOLE PROPERTY OF PARKWAY PLASTICS INC. ANY REPRODUCTION IN PART OR AS A WHOLE WITHOUT THE WRITTEN PERMISSION OF PARKWAY PLASTICS INC IS PROHIBITED.

UNCONTROLLED COPY