

PROPERTY OF

PPI IS NOT RESPONSIBLE FOR PRODUCT COMPATABILITY.
NOT ALL MATERIALS ARE SUITABLE FOR ALL APPLICATIONS.



PARKWAY PLASTICS

IT IS THE BUYER'S SOLE RESPONSIBILITY TO TEST THE COMPATIBILITY
OF THEIR PRODUCTS WITH PARKWAY'S PRODUCTS & SERVICES.

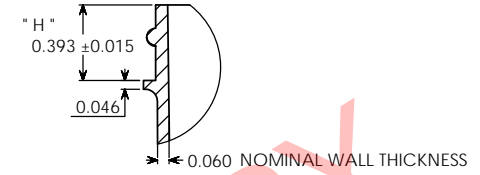
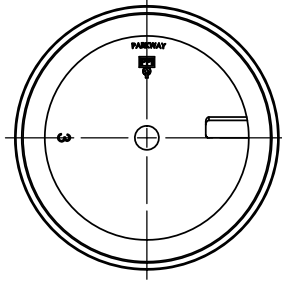

DETAIL B
SCALE 2 : 1

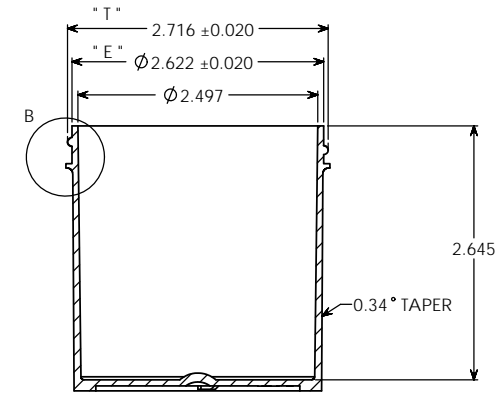
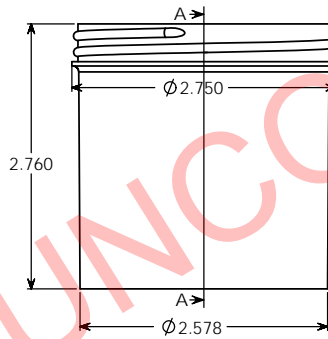

SECTION A-A

NOTE

Manufacturer reserves the right to change specifications without notice. All purchase order for the item herein described, must be accompanied by a copy of this print. All dimensions have a tolerance of +/- 3 % unless otherwise specified.
SIDEWALL CAMBER .050" PER SIDE MAX.
THREAD = GCM1 400- CT FINISH
6 THREADS PER INCH.

OVERFLOW: 204 ML
WEIGHT: 31 GRAMS ± 3 GRAMS

UNCONTROLLED COPY

PROPRIETARY AND CONFIDENTIAL
THE INFORMATION CONTAINED IN THIS DRAWING IS THE SOLE PROPERTY OF PARKWAY PLASTICS INC. ANY REPRODUCTION IN PART OR AS A WHOLE WITHOUT THE WRITTEN PERMISSION OF PARKWAY PLASTICS INC IS PROHIBITED.

| | | | | | | |
|-----------------|-----------------|-----------------------------------------------------------------------------------------|-----------|-------|----------------------|----------|
| * T * DIMENSION | 2.716 ± 0.020 | UNLESS OTHERWISE SPECIFIED: | NAME | DATE | PARKWAY PLASTICS INC | |
| * E * DIMENSION | 2.622 ± 0.020 | DIMENSIONS ARE IN INCHES | DRAWN | G.W.W | | 01/25/13 |
| * H * DIMENSION | 0.393 ± 0.015 | TOLERANCES: | CHECKED | | | |
| SECTION VIEW | JAR | FRACTIONAL * ANGULAR * MACH * BEND * TWO PLACE DECIMAL * THREE PLACE DECIMAL * | ENG APPR | | | |
| DETAIL VIEW | A - A | MATERIAL | MFG APPR | | | |
| | B | U11 | D.A. | | | |
| | * H * DIMENSION | REPLACES PRINT | COMMENTS: | | | |
| | | NA | # 670SRWJ | | | |
| NEXT ASSY | USED ON | DECORATION | | | | |
| | | DO NOT SCALE DRAWING | | | | |
| APPLICATION | | | | | | |

| | | |
|------------|------------------------------------------------------|--------------|
| TITLE: | 6 OZ 70 MM REGULAR WALL STYRENE JAR (CUSTOMER PRINT) | |
| SIZE | DWG. NO. | REV |
| C | A0700600CSC | |
| SCALE: 1:1 | WEIGHT: | SHEET 1 OF 1 |