

PROPERTY OF

PPI IS NOT RESPONSIBLE FOR PRODUCT COMPATABILITY.
NOT ALL MATERIALS ARE SUITABLE FOR ALL APPLICATIONS.



PARKWAY PLASTICS

IT IS THE BUYER'S SOLE RESPONSIBILITY TO TEST THE COMPATIBILITY
OF THEIR PRODUCTS WITH PARKWAY'S PRODUCTS & SERVICES.

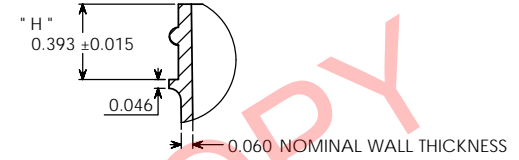
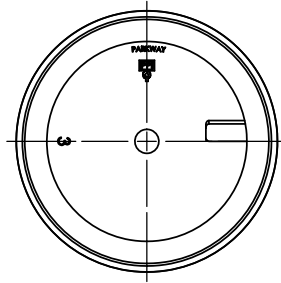

DETAIL B
SCALE 2 : 1

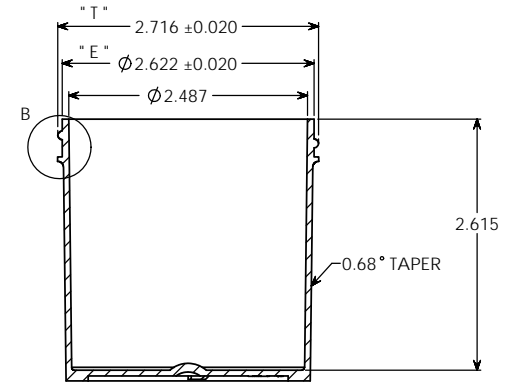
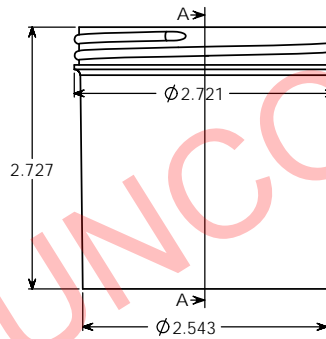

SECTION A-A

NOTE

Manufacturer reserves the right to change specifications without notice. All purchase order for the item herein described, must be accompanied by a copy of this print. All dimensions have a tolerance of +/- 3 % unless otherwise specified.
SIDEWALL CAMBER .050° PER SIDE MAX.
THREAD = GCM1 400- CT FINISH
6 THREADS PER INCH.

OVERFLOW: 204 ML
WEIGHT: 26 GRAMS ± 3 GRAMS

UNCONTROLLED COPY

PROPRIETARY AND CONFIDENTIAL
THE INFORMATION CONTAINED IN THIS DRAWING IS THE SOLE PROPERTY OF PARKWAY PLASTICS INC. ANY REPRODUCTION IN PART OR AS A WHOLE WITHOUT THE WRITTEN PERMISSION OF PARKWAY PLASTICS INC IS PROHIBITED.

* T * DIMENSION	2.716 ± 0.020	UNLESS OTHERWISE SPECIFIED:	NAME	DATE	PARKWAY PLASTICS INC	
* E * DIMENSION	2.622 ± 0.020	DIMENSIONS ARE IN INCHES	DRAWN	G.W.W		01/25/13
* H * DIMENSION	0.393 ± 0.015	TOLERANCES:	CHECKED			
SECTION VIEW A - A	JAR	FRACTIONAL ± ANGULAR MATCH ± BEND ± TWO PLACE DECIMAL ± THREE PLACE DECIMAL ±	ENG APPR			
DETAIL VIEW B	* H * DIMENSION	MATERIAL	D.A.	COMMENTS:		
		S10-01				
		COLOR/AN				
		DECORATION	NA	REPLACES PRINT # 670PPRWJ		
NEXT ASSY	USED ON					
APPLICATION	DO NOT SCALE DRAWING					

TITLE:	6 OZ 70 MM REGULAR WALL POLYPROPYLENE JAR (CUSTOMER PRINT)		
SIZE	DWG. NO.	REV	
C	A0700600PPC		
SCALE: 1:1	WEIGHT:		SHEET 1 OF 1