

PROPERTY OF

PPI IS NOT RESPONSIBLE FOR PRODUCT COMPATABILITY.  
NOT ALL MATERIALS ARE SUITABLE FOR ALL APPLICATIONS.



PARKWAY PLASTICS

IT IS THE BUYER'S SOLE RESPONSIBILITY TO TEST THE COMPATIBILITY  
OF THEIR PRODUCTS WITH PARKWAY'S PRODUCTS & SERVICES.

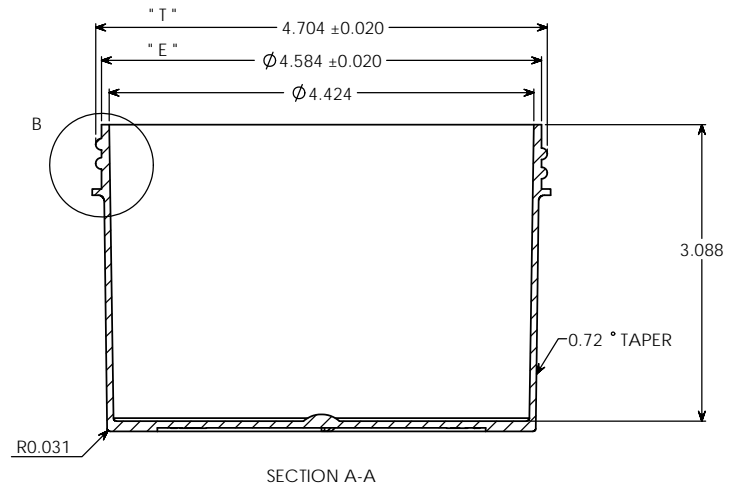
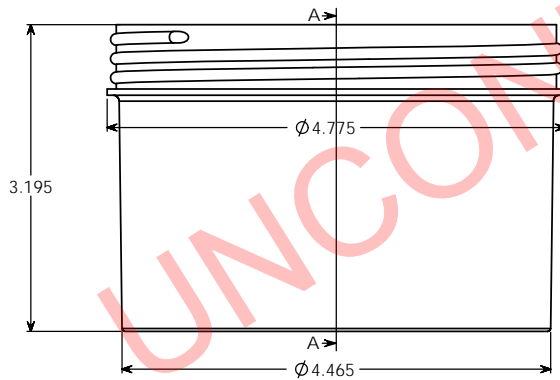
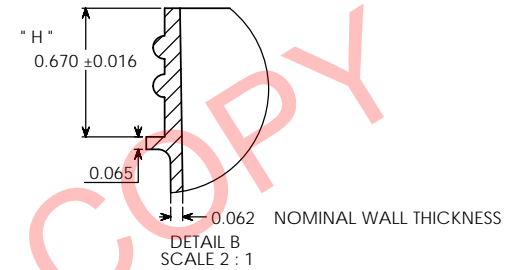
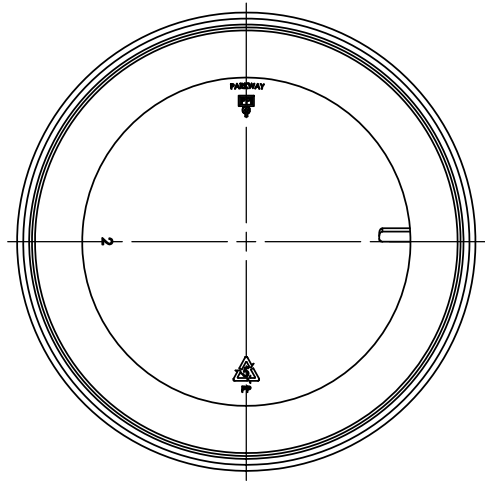

NOTE

Manufacturer reserves the right to change specifications without notice. All purchase order for the item herein described, must be accompanied by a copy of this print. All dimensions have a tolerance of +/- 3% unless otherwise specified.  
SIDEWALL CAMBER .050" PER SIDE MAX.  
THREAD = GCM1 400-CT FINISH  
5 THREADS PER INCH.

OVERFLOW: 777 ML  
WEIGHT: 65 GRAMS ± 5 GRAMS

PROPRIETARY AND CONFIDENTIAL  
THE INFORMATION CONTAINED IN THIS DRAWING IS THE SOLE PROPERTY OF PARKWAY PLASTICS INC. ANY REPRODUCTION IN PART OR AS A WHOLE WITHOUT THE WRITTEN PERMISSION OF PARKWAY PLASTICS INC IS PROHIBITED.

* T * DIMENSION	4.704 ± 0.020	UNLESS OTHERWISE SPECIFIED:	NAME	DATE	PARKWAY PLASTICS INC
* E * DIMENSION	4.584 ± 0.020	DIMENSIONS ARE IN INCHES	G.W.W	02/12/13	
* H * DIMENSION	0.670 ± 0.016	FRACTIONAL * ANGULAR MATCH * BEND * TWO PLACE DECIMAL * THREE PLACE DECIMAL *	CHECKED		
SECTION VIEW A-A	JAR	MATERIAL	ENG APPR		
DETAIL VIEW B	* H * DIMENSION	S11	MFG APPR		TITLE:
		61 WHITE	D.A.		24 OZ 120 MM REGULAR WALL WHITE POLYPROPYLENE JAR (CUSTOMER PRINT)
		NA	COMMENTS:		SIZE DWG. NO.
NEXT ASSY	USED ON	DECORATION			C A1202400PPW
APPLICATION	DO NOT SCALE DRAWING				SCALE: 1:1 WEIGHT: SHEET 1 OF 1

UNCONTROLLED COPY