

PROPERTY OF

PPI IS NOT RESPONSIBLE FOR PRODUCT COMPATABILITY.  
NOT ALL MATERIALS ARE SUITABLE FOR ALL APPLICATIONS.



PARKWAY PLASTICS

IT IS THE BUYER'S SOLE RESPONSIBILITY TO TEST THE COMPATIBILITY  
OF THEIR PRODUCTS WITH PARKWAY'S PRODUCTS & SERVICES.

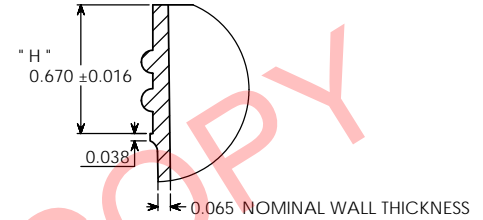
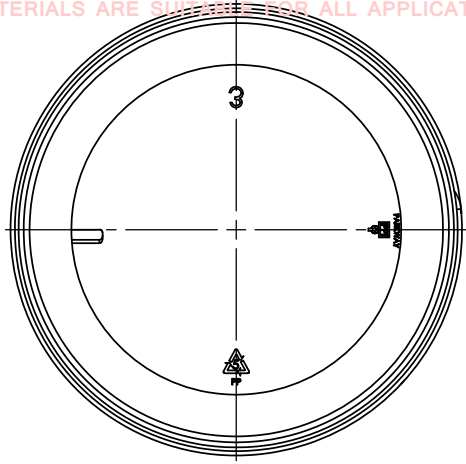

DETAIL B  
SCALE 2 : 1

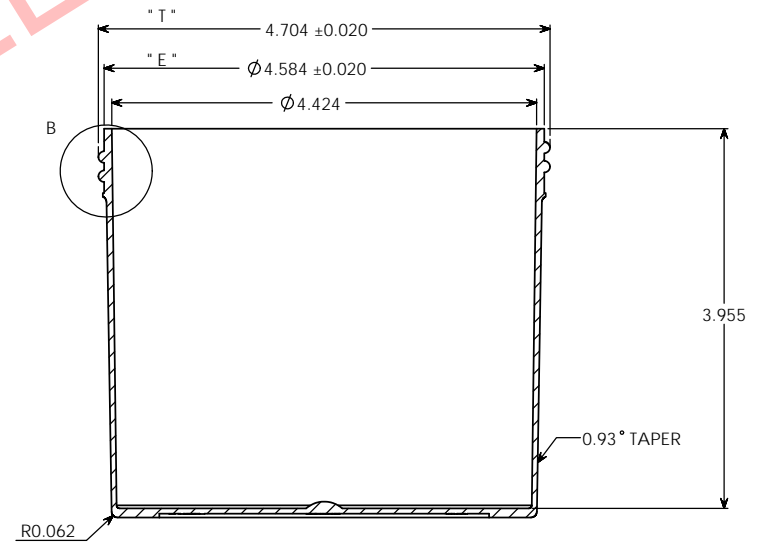
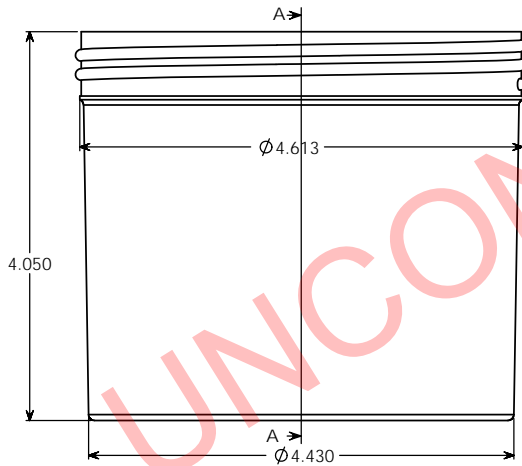

SECTION A-A

NOTE

Manufacturer reserves the right to change specifications without notice. All purchase order for the item herein described, must be accompanied by a copy of this print. All dimensions have a tolerance of +/- 3 % unless otherwise specified.  
SIDEWALL CAMBER .050" PER SIDE MAX.  
THREAD = GCM1 400- CT FINISH  
5 THREADS PER INCH.

OVERFLOW: 975 ML  
WEIGHT: 68 GRAMS ± 6 GRAMS

PROPRIETARY AND CONFIDENTIAL  
THE INFORMATION CONTAINED IN THIS DRAWING IS THE SOLE PROPERTY OF PARKWAY PLASTICS INC. ANY REPRODUCTION IN PART OR AS A WHOLE WITHOUT THE WRITTEN PERMISSION OF PARKWAY PLASTICS INC IS PROHIBITED.

* T * DIMENSION	4.704 ± 0.020	UNLESS OTHERWISE SPECIFIED:	NAME	DATE	PARKWAY PLASTICS INC	
* E * DIMENSION	4.584 ± 0.020	DIMENSIONS ARE IN INCHES	DRAWN	G.W.W		02/13/13
* H * DIMENSION	0.670 ± 0.016	TOLERANCES: FRACTIONAL ± ANGULAR MATCH ± BEND ± TWO PLACE DECIMAL ± THREE PLACE DECIMAL ±	CHECKED			
SECTION VIEW A - A	JAR	MATERIAL	ENG APPR			
DETAIL VIEW B	* H * DIMENSION	S 10 -01	MFG APPR			
		COLORS/ANI	QA			
		DECORATION	COMMENTS			
NEXT ASSY	USED ON	NA	REPLACES PRINT # 32120PPR			
APPLICATION	DO NOT SCALE DRAWING					

TITLE:  
32 OZ 120 MM REGULAR WALL  
POLYPROPYLENE JAR  
(CUSTOMER PRINT)

SIZE DWG. NO. REV  
C A1203200PPC  
SCALE: 1:1 WEIGHT: SHEET 1 OF 1