

PROPERTY OF

PPI IS NOT RESPONSIBLE FOR PRODUCT COMPATABILITY.  
NOT ALL MATERIALS ARE SUITABLE FOR ALL APPLICATIONS.



PARKWAY PLASTICS

IT IS THE BUYER'S SOLE RESPONSIBILITY TO TEST THE COMPATIBILITY  
OF THEIR PRODUCTS WITH PARKWAY'S PRODUCTS & SERVICES.

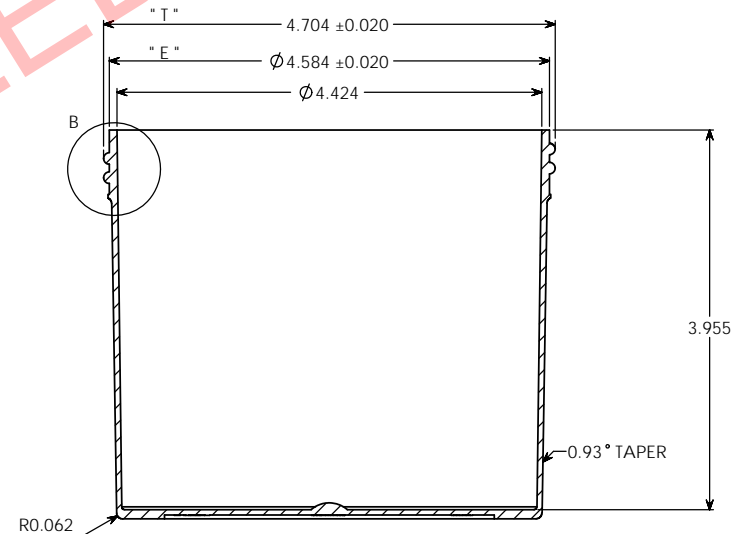
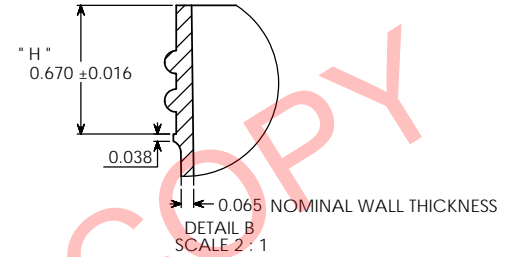
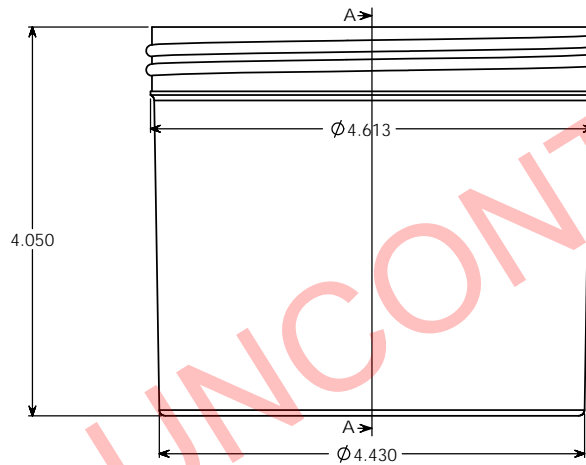
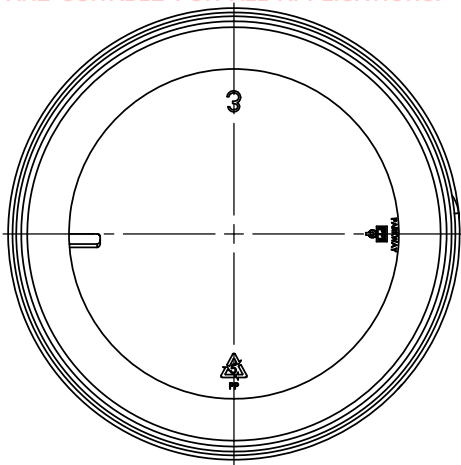

NOTE

Manufacturer reserves the right to change specifications without notice. All purchase order for the item herein described, must be accompanied by a copy of this print. All dimensions have a tolerance of +/- 3% unless otherwise specified.  
SIDEWALL CAMBER .050" PER SIDE MAX.  
THREAD = GCM1 400- CT FINISH  
5 THREADS PER INCH.

OVERFLOW: 975 ML  
WEIGHT: 68 GRAMS ± 6 GRAMS

PROPRIETARY AND CONFIDENTIAL  
THE INFORMATION CONTAINED IN THIS DRAWING IS THE SOLE PROPERTY OF PARKWAY PLASTICS INC. ANY REPRODUCTION IN PART OR AS A WHOLE WITHOUT THE WRITTEN PERMISSION OF PARKWAY PLASTICS INC IS PROHIBITED.

* T * DIMENSION	4.704 ± 0.020	UNLESS OTHERWISE SPECIFIED: DIMENSIONS ARE IN INCHES TOLERANCES: FRACTIONAL * ANGULAR: MATCH * BEND * TWO PLACE DECIMAL * THREE PLACE DECIMAL *	DRAWN	NAME	DATE	PARKWAY PLASTICS INC TITLE: 32 OZ 120 MM REGULAR WALL WHITE POLYPROPYLENE JAR (CUSTOMER PRINT)
* E * DIMENSION	4.584 ± 0.020		CHECKED	G.W.W	02/13/13	
* H * DIMENSION	0.670 ± 0.016		ENG APPR			SIZE DWG. NO. REV C A1203200PPW
SECTION VIEW A - A	JAR		MFG APPR			
DETAIL VIEW B	* H * DIMENSION		D.A.			SCALE: 1:1 WEIGHT: SHEET 1 OF 1
			COMMENTS:			
NEXT ASSY	USED ON					
APPLICATION	DO NOT SCALE DRAWING					

UNCONTROLLED COPY