

PROPERTY OF

PPI IS NOT RESPONSIBLE FOR PRODUCT COMPATABILITY.
NOT ALL MATERIALS ARE SUITABLE FOR ALL APPLICATIONS.



PARKWAY PLASTICS

IT IS THE BUYER'S SOLE RESPONSIBILITY TO TEST THE COMPATIBILITY
OF THEIR PRODUCTS WITH PARKWAY'S PRODUCTS & SERVICES.

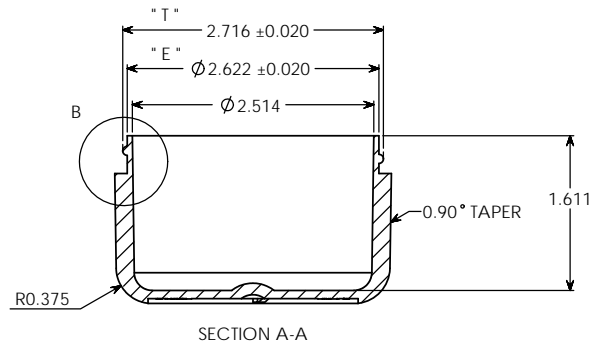
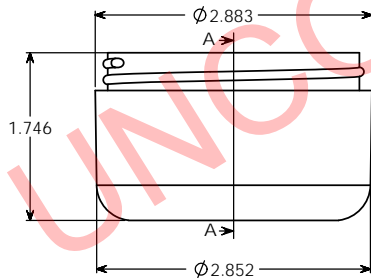
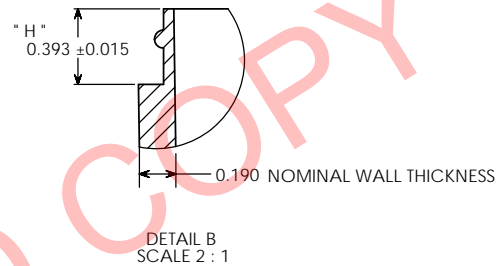
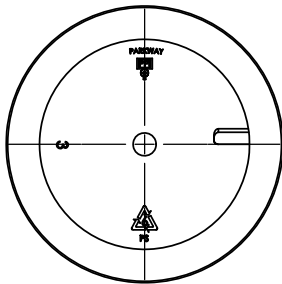

NOTE

Manufacturer reserves the right to change specifications without notice. All purchase order for the item herein described, must be accompanied by a copy of this print. All dimensions have a tolerance of +/- 3 % unless otherwise specified.
SIDEWALL CAMBER .050° PER SIDE MAX.
THREAD = GCM1 400- CT FINISH
6 THREADS PER INCH.

OVERFLOW: 138 ML
WEIGHT: 44.6 GRAMS ± 2 GRAMS

PROPRIETARY AND CONFIDENTIAL
THE INFORMATION CONTAINED IN THIS DRAWING IS THE SOLE PROPERTY OF PARKWAY PLASTICS INC. ANY REPRODUCTION IN PART OR AS A WHOLE WITHOUT THE WRITTEN PERMISSION OF PARKWAY PLASTICS INC IS PROHIBITED.

* T * DIMENSION	2.716 ± 0.020	UNLESS OTHERWISE SPECIFIED: DIMENSIONS ARE IN INCHES TOLERANCES: FRACTIONAL ± ANGULAR MATCH ± BEND ± TWO PLACE DECIMAL ± THREE PLACE DECIMAL ±	NAME	DATE	PARKWAY PLASTICS INC TITLE: 3 OZ 70 MM THICK WALL ROUND BOTTOM STYRENE	
* E * DIMENSION	2.622 ± 0.020		DRAWN	G.W.W		08/12/13
* H * DIMENSION	0.393 ± 0.015	CHECKED				
SECTION VIEW A-A	JAR	ENG APPR				
DETAIL VIEW B	* H * DIMENSION	MATERIAL	CUSTOMER PART #		SIZE DWG. NO. REV C B0700300CSCR	
		COLOR/GRN				
		DECORATION				
DO NOT SCALE DRAWING					SCALE: 1:1	SHEET 1 OF 1