

PROPERTY OF

PPI IS NOT RESPONSIBLE FOR PRODUCT COMPATABILITY.
NOT ALL MATERIALS ARE SUITABLE FOR ALL APPLICATIONS.



PARKWAY PLASTICS

IT IS THE BUYER'S SOLE RESPONSIBILITY TO TEST THE COMPATIBILITY
OF THEIR PRODUCTS WITH PARKWAY'S PRODUCTS & SERVICES.

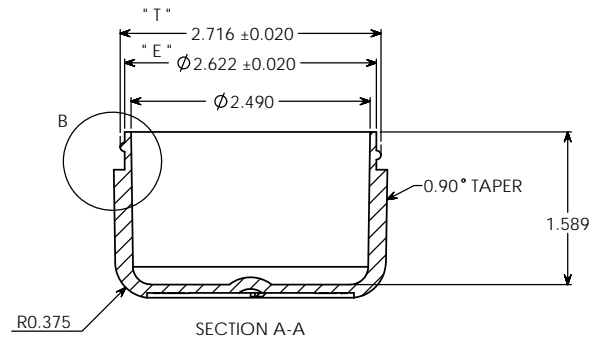
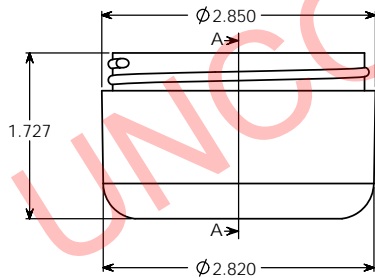
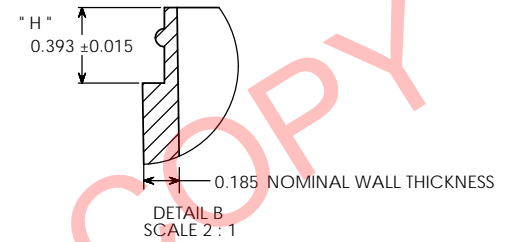
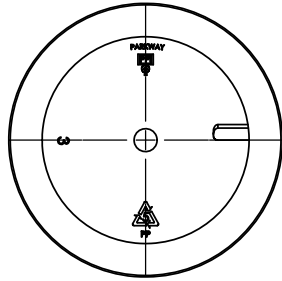

NOTE

=====
Manufacturer reserves the right to change specifications without notice. All purchase order for the item herein described, must be accompanied by a copy of this print. All dimensions have a tolerance of +/- 3 % unless otherwise specified.
SIDEWALL CAMBER .050" PER SIDE MAX.
THREAD = GCM1 400- CT FINISH
6 THREADS PER INCH.

OVERFLOW: 131 ML
WEIGHT: 37.8 GRAMS ± 2 GRAMS

UNCONTROLLED COPY

PROPRIETARY AND CONFIDENTIAL
THE INFORMATION CONTAINED IN THIS DRAWING IS THE SOLE PROPERTY OF PARKWAY PLASTICS INC. ANY REPRODUCTION IN PART OR AS A WHOLE WITHOUT THE WRITTEN PERMISSION OF PARKWAY PLASTICS INC IS PROHIBITED.

* T * DIMENSION	2.716 ± 0.020	UNLESS OTHERWISE SPECIFIED:	NAME	DATE	PARKWAY PLASTICS INC
* E * DIMENSION	2.622 ± 0.020	DIMENSIONS ARE IN INCHES	G.W.W	08/12/13	
* H * DIMENSION	0.393 ± 0.015	TOLERANCES:	CHECKED		TITLE:
SECTION VIEW A - A	JAR	FRACTIONAL ±	ENG APPR		3 OZ 70 MM THICK WALL ROUND BOTTOM WHITE POLYPROPYLENE JAR
DETAIL VIEW B	* H * DIMENSION	ANGULAR MATCH ± BEND ±	MFG APPR		
		TWO PLACE DECIMAL ±	D.A.		SIZE
		THREE PLACE DECIMAL ±	CUSTOMER PART #		DWG. NO.
		MATERIAL			B0700300PPWR
		COLORANT			REV
		DECORATION			
					SCALE: 1:1
					SHEET 1 OF 1

DO NOT SCALE DRAWING