

PROPERTY OF

PPI DOESN'T MAKE ANY WARRANTIES REGARDING MERCHANTABILITY.  
NOT ALL MATERIALS ARE SUITABLE FOR ALL APPLICATIONS.



PARKWAY PLASTICS

IT IS THE BUYER'S SOLE RESPONSIBILITY TO TEST THE COMPATIBILITY OF THEIR PRODUCTS WITH PARKWAY'S PRODUCTS & SERVICES.

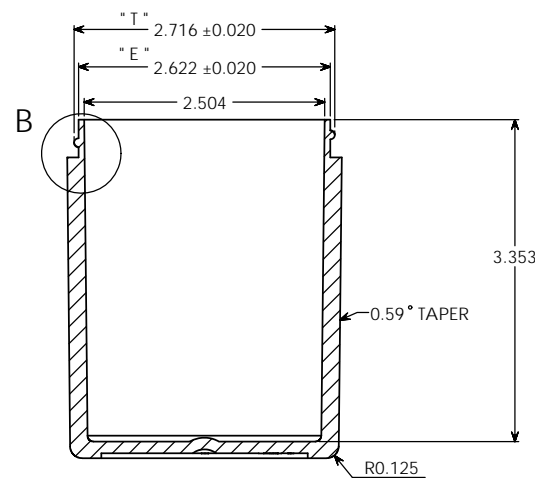
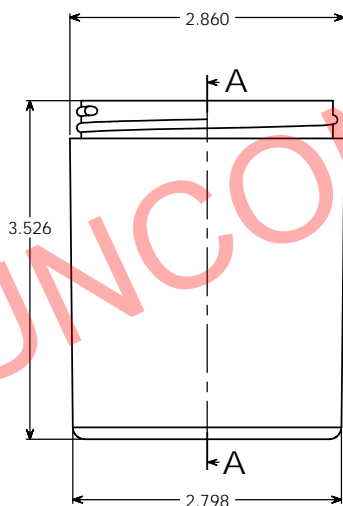
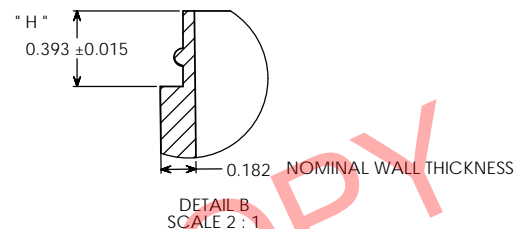
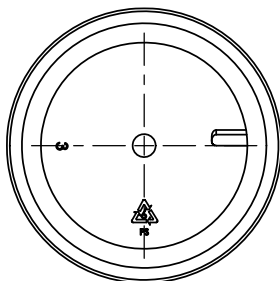

SECTION A-A

NOTE

=====  
Manufacturer reserves the right to change specifications without notice. All purchase order for the item herein described, must be accompanied by a copy of this print. All dimensions have a tolerance of +/- 3 % unless otherwise specified.  
SIDEWALL CAMBER .050° PER SIDE MAX.  
THREAD = GCM1 400- CT FINISH  
6 THREADS PER INCH.

OVERFLOW VOLUME: 275 ML  
WEIGHT: 94 GRAMS ± 5 GRAMS

UNCONTROLLED COPY

PROPRIETARY AND CONFIDENTIAL  
THE INFORMATION CONTAINED IN THIS DRAWING IS THE SOLE PROPERTY OF PARKWAY PLASTICS INC. ANY REPRODUCTION IN PART OR AS A WHOLE WITHOUT THE WRITTEN PERMISSION OF PARKWAY PLASTICS INC IS PROHIBITED.

* T * DIMENSION	2.716 ± 0.020	UNLESS OTHERWISE SPECIFIED: DIMENSIONS ARE IN INCHES	NAME	DATE	PARKWAY PLASTICS INC	
* E * DIMENSION	2.622 ± 0.020		DRAWN	G.W.W		11/10/15
* H * DIMENSION	0.393 ± 0.015		CHECKED	G.W.W		09/28/16
SECTION VIEW A - A	JAR	MATERIAL	U11	ENG APPR	TITLE: 8 OZ 70 MM THICK WALL STYRENE JAR	
DETAIL VIEW B	* H * DIMENSION	COLORANT	NA	MFG APPR		
		DECORATION	NA	D.A.		
		CASE COUNT	NA	COMMENTS:	SIZE DWG. NO. REV	
		PACKING METHOD	NA		C B0700800CSC	
DO NOT SCALE DRAWING					SCALE: 1:1 SHEET 1 OF 1	