

PROPERTY OF

PPI IS NOT RESPONSIBLE FOR PRODUCT COMPATABILITY.
NOT ALL MATERIALS ARE SUITABLE FOR ALL APPLICATIONS.



PARKWAY PLASTICS

IT IS THE BUYER'S SOLE RESPONSIBILITY TO TEST THE COMPATIBILITY OF
THEIR PRODUCTS WITH PARKWAY'S PRODUCTS & SERVICES.

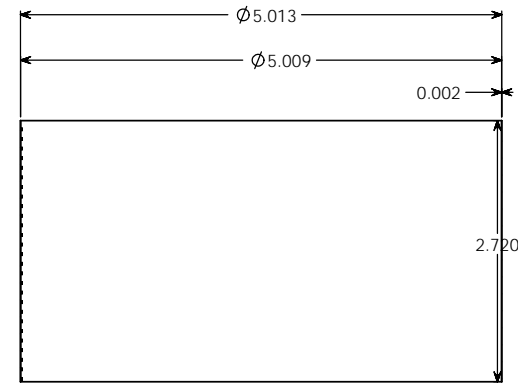
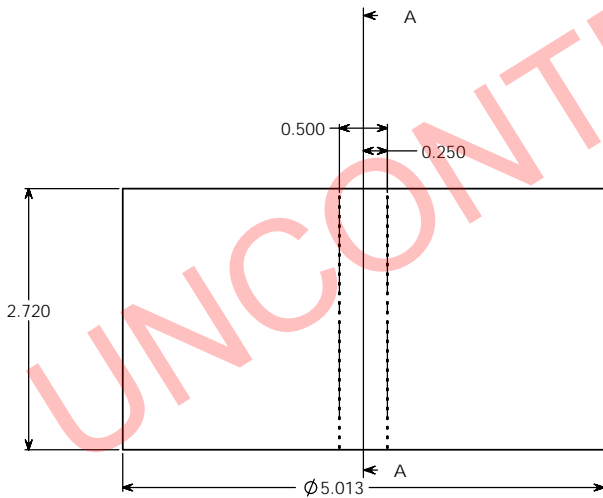
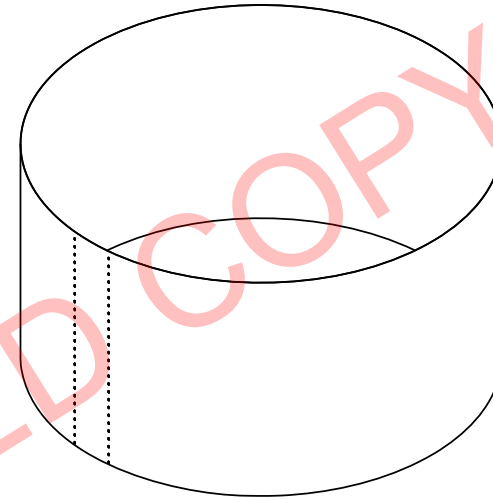
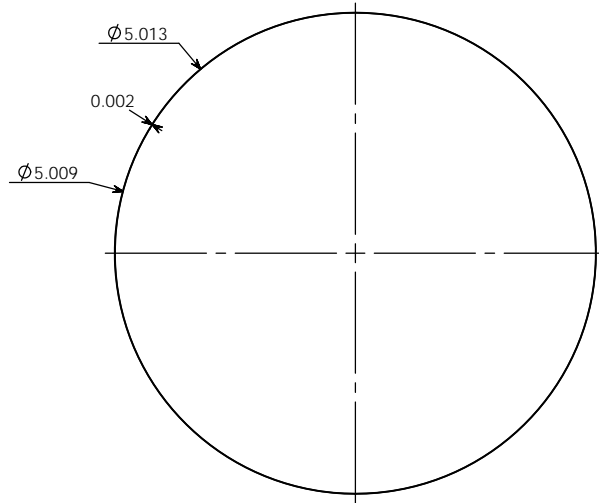

SECTION A-A

NOTE:

SHRINKSLEEVES ARE SHIPPED
PRESSED FLAT WITH SPECIFIC WIDTH
& HEIGHT MEASUREMENTS. EACH
MEASUREMENT HAS A TOLERANCE
OF +/- .125 INCHES (3.175 MM).

PROPRIETARY AND CONFIDENTIAL
THE INFORMATION CONTAINED IN THIS
DRAWING IS THE SOLE PROPERTY OF
PARKWAY PLASTICS INC. ANY
REPRODUCTION IN PART OR AS A WHOLE
WITHOUT THE WRITTEN PERMISSION OF
PARKWAY PLASTICS INC IS PROHIBITED.

WIDTH	HEIGHT	UNLESS OTHERWISE SPECIFIED:	NAME	DATE	PARKWAY PLASTICS INC
200MM	69MM	DIMENSIONS ARE IN INCHES TOLERANCES: FRACTIONAL ± ANGULAR MATCH ± BEND ± TWO PLACE DECIMAL ± THREE PLACE DECIMAL ±	S.P.	02/05/15	
		INTERPRET GEOMETRIC TOLERANCING PER:	CHECKED		TITLE:
		MATERIAL	ENG APPR		16OZ 120MM TW CLEAR PVC SHRINK SLEEVE
NEXT ASSY	USED ON	FINISH	MFG APPR		SIZE DWG. NO. REV
APPLICATION		DO NOT SCALE DRAWING	D.A.		C B1201600 Shrink Sleeve
			COMMENTS:		SCALE: 1:1 WEIGHT: SHEET 1 OF 1

PROPERTY OF

PPI IS NOT RESPONSIBLE FOR PRODUCT COMPATABILITY.
NOT ALL MATERIALS ARE SUITABLE FOR ALL APPLICATIONS.



PARKWAY PLASTICS

IT IS THE BUYER'S SOLE RESPONSIBILITY TO TEST THE COMPATIBILITY OF
THEIR PRODUCTS WITH PARKWAY'S PRODUCTS & SERVICES.

**16OZ 120MM TW CLEAR PVC SHRINK SLEEVE
200MM X 69MM**

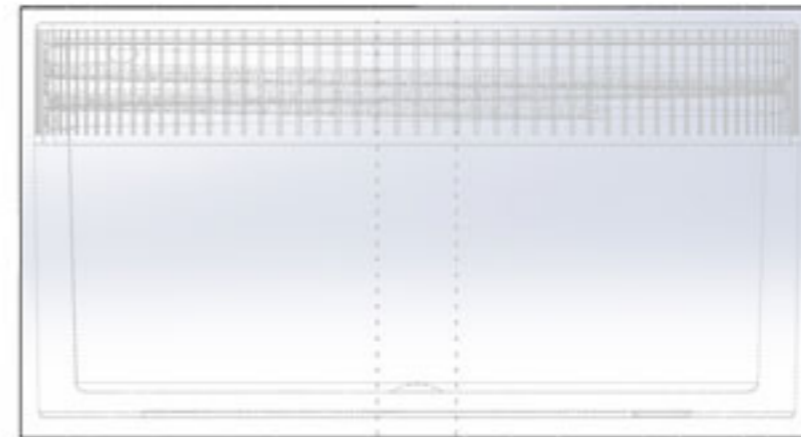

UNCONTROLLED COPY